

Manitowoc Cranes

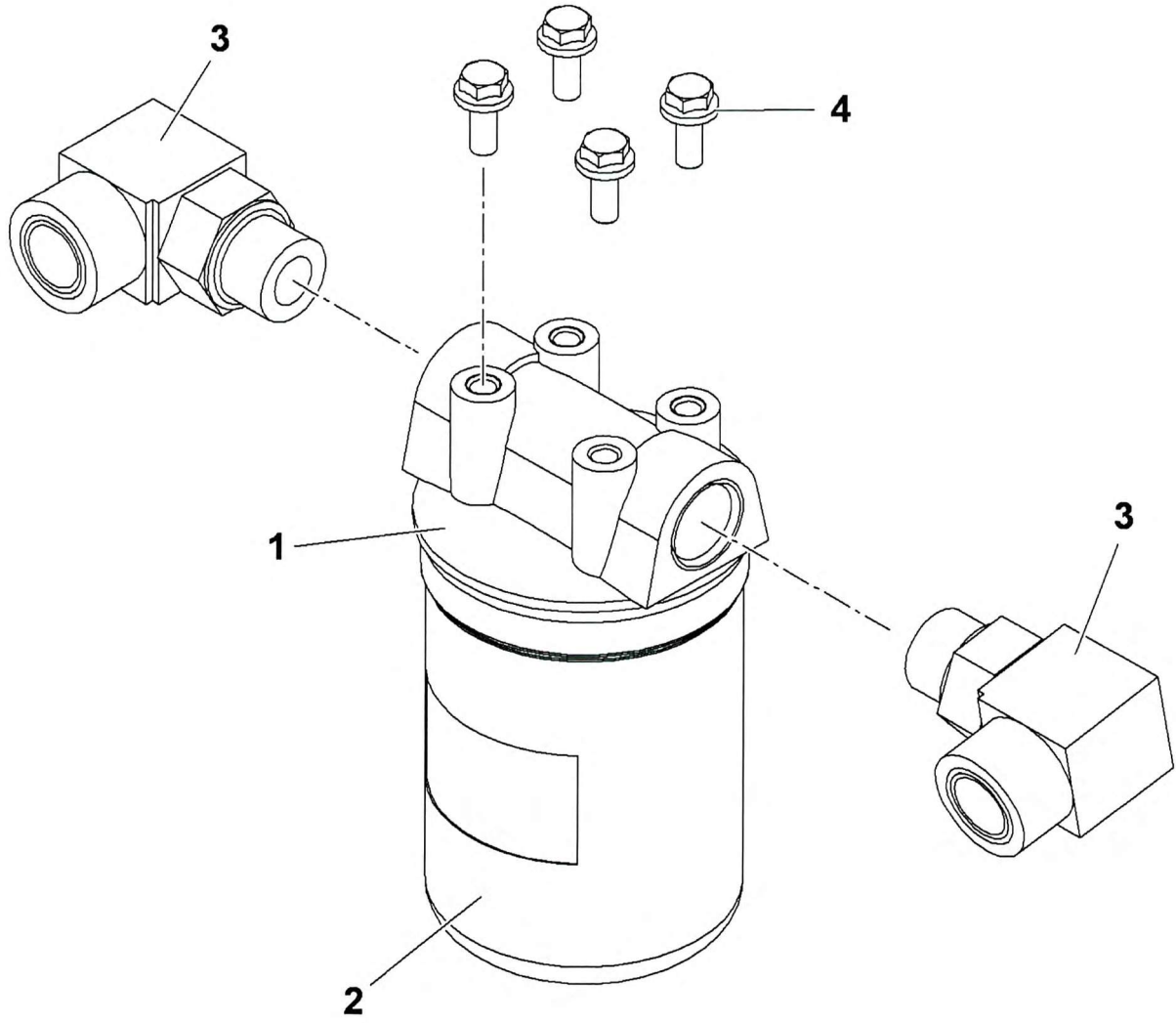

WIRE NO	COLOR	SAE SIZE	LENGTH TOT IN	TP	B/M ITEM NO	REMARKS	TP	B/M ITEM NO	REMARKS
7	WHT GXL	18	96	C	44		K	39,40	
25		18	110	C	44		P	60	
51A		16	85	C	44		S3	STRIP	SEE DETAIL
51B		18	11	K	39,40		S3	STRIP	SEE DETAIL
51C		18	11	L	39,40		S3	STRIP	SEE DETAIL
51D		18	11	M	39,40		S3	STRIP	SEE DETAIL
51E		18	11	N	39,40		S3	STRIP	SEE DETAIL
51F		18	243	W	42		S3	STRIP	SEE DETAIL
89A		16	142	C	44		T	41	
344A		12	35	C	45		S2	STRIP	SEE DETAIL
344B		12	35	C	45		S2	STRIP	SEE DETAIL
344C		18	37	A	42		S2	STRIP	SEE DETAIL
344D		18	37	A	42		S2	STRIP	SEE DETAIL
344E		18	37	A	42		S2	STRIP	SEE DETAIL
344F		18	37	A	42		S2	STRIP	SEE DETAIL
345A		6	91	V	61		S1	STRIP	SEE DETAIL
345B		18	35	A	42		S1	STRIP	SEE DETAIL
345C		18	35	A	42		S1	STRIP	SEE DETAIL
345D		18	35	A	42		S1	STRIP	SEE DETAIL
345E		18	35	A	42		S1	STRIP	SEE DETAIL
345F		12	30	G	64		S1	STRIP	SEE DETAIL
367		18	96	C	44		M	39,40	
368		18	96	C	44		N	39,40	
371		18	96	C	44		L	39,40	
596		18	144	C	44		R	33,34	
645		18	72	A	42		C	44	
1091A		18	200	A	42		E	71	
1160		18	72	A	42		C	44	
1280		18	60	C	44		H	44	
1281		18	3	A	42		A	SEE CABLE	DET ES & CL
1283		18	72	A	42		C	44	
1299		18	60	C	44		H	44	
1532		18	3	A	42		A	SEE CABLE	DET ES & CL
1536		18	200	A	42		E	71	
1537		18	200	A	42		E	71	
1538		18	200	A	42		E	71	
1559A		18	230	W	42		C	44	
2164		18	72	A	42		C	44	
SHD1		18	3	J	41		J	SEE CABLE	DET J1939A
SHD2	WHT GXL	18	3	J	41		J	SEE CABLE	DET J1939B
SHD3	WHT GXL	18	3	C	44		C	SEE CABLE	DET J1939B

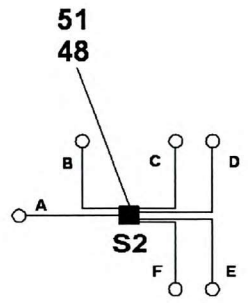

DETAIL 344

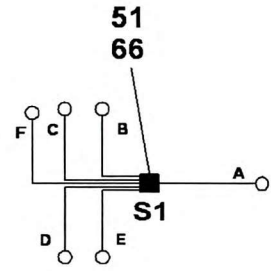

DETAIL 345

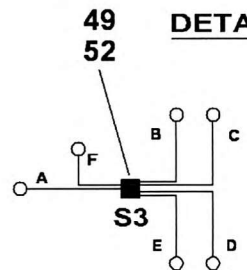

DETAIL 51

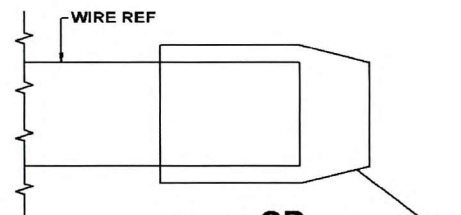

DETAIL CD
WIRE ENDS TYP

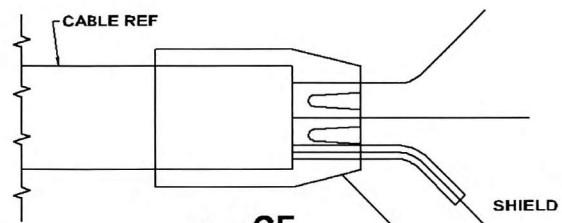

DETAIL CE
CABLE ENDS TYP-BOTH ENDS

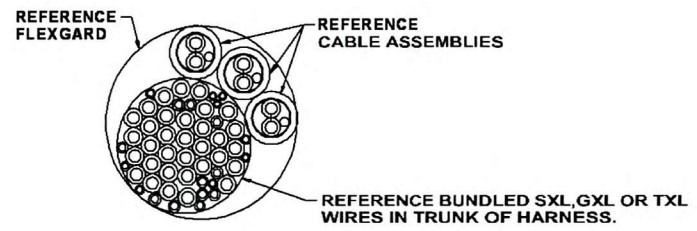

DETAIL BDR
WIRE/CABLE BUNDLING

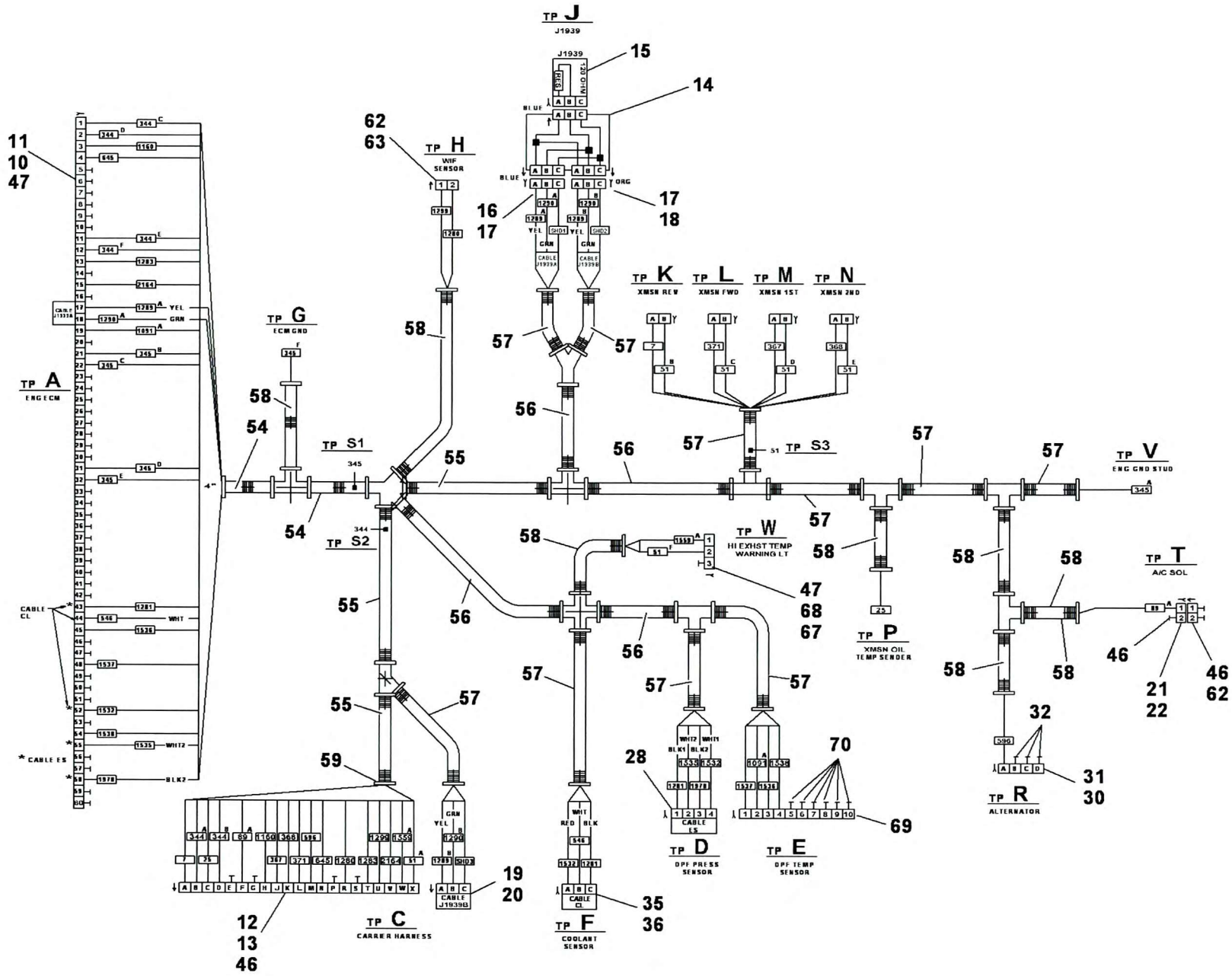

80024458

(SHEET 1 OF 2)
Page 672